

INSTALLATION INSTRUCTIONS for HeatManager™ 2.5 model 7514

Form 7514 rev. 0

LIGHT COMMERCIAL HYDRONIC HEATING SYSTEM ECONOMIZER

Description

The HeatManager™2.5 is a patented microprocessor-controlled fuel-saving device for commercial and residential hydronic heating systems. It reduces fuel consumption, wear on boiler parts and burner emissions by actively managing the burner, in conjunction with the boiler aquastat, to properly match the boiler output to the required load.

Operation

After installation, setting the toggle switch on the unit to the 'ON' position activates the device. The LCD display indicates the various 'modes' of the device, and sensed temperatures. The possible messages and their explanation are:

'STANDBY MODE' - The boiler is operating under its own internal aquastat, which has turned the burner off. This occurs for a period of time after the burner has shut down.

'ECONOMIZER MODE' - The boiler aquastat has requested the burner to come on but the HeatManager™ has sensed that there is available heat which can be used without burning fuel. The burner will remain off and useful heat will be delivered from the boiler's existing supply of hot water.

'HEATING MODE' - The burner is allowed to fire.

'HEATING LOW LIMIT' - The unit has switched the burner on due to an increase in load. This condition may occur occasionally. If this message appears frequently, the boiler aquastat is set at too low a temperature. It should be increased in 2° F increments until the condition stops.

During normal operation, one of the above messages will be alternated with the message(s) below.

'HEAT TEMP = ' - The measured value of the boiler outflow water temperature is displayed in degrees F.

'DOM. TEMP = ' - The measured value of the domestic hot water outflow temperature is displayed in degrees F. *

* Note: This message will only appear if the boiler supplies domestic hot water and the optional second sensor is installed (see Sensor Section of these instructions).

In the event that a sensor fails, the HEATMANAGER™ will return full control of the burner to the boiler aquastat, the 'Power/Normal' indicator will blink, and the following message will be display:

'SENSOR FAILURE'

If this message appears, see the instructions under **Service and Troubleshooting** or call your installer for service.

Installation

The HEATMANAGER™ unit is electrically installed in series with the boiler aquastat as shown in the wiring diagram (Fig. 1a or Fig.1b on the reverse side of this page). Check the shipping box label for correct model. The HEATMANAGER™ can be used with 24, 115 and 220 Volts AC (see Fig. 1a or Fig. 1b for wiring details) for power and control.

For safety, power to the boiler should be shut off during installation.

To ensure maximum savings, it is recommended that the Aquastat be set to a minimum of 170°F.

Positioning

The unit can be mounted in any position. For readability of the display, the vertical position is preferred. Depending on the boiler's configuration, the unit can be mounted on an electric junction box or directly on an external aquastat. Remove a knockout from the junction box or aquastat and mount the unit using the standard ½' electrical fitting on the case, and the supplied lock-nut.

Wiring

All wiring and connections must comply with Local and National Electrical Codes. The unit should be wired as shown in the wiring diagram (Fig. 1a or Fig. 1b) on the reverse side.

NOTE: All unused leads should be trimmed and individually taped.

Sensors

Insert the sensor connector into the 'Heating Water Sensor' jack in the side of the unit. Attach the sensor to the boiler outflow pipe using Ty-Wraps® (see Fig. 2) or another secure method. Make sure that the sensor makes good thermal contact with the pipe. Cover the sensor with a small piece of pipe insulation (not provided) and secure in place (see Fig. 3).

For boilers which also supply domestic hot water, install a second sensor in the 'Domestic Water Sensor' jack and attach the sensor end to the domestic hot water outflow-pipe at the storage tank, if present, or at the boiler domestic water coil outlet-pipe, if no storage tank is used. Follow the same procedure to attach the sensor as used above for the 'Heating Water Sensor'. This sensor should not be used if the boiler does not supply heat for domestic hot water.

If any of the sensor leads are too short, they can be extended by using standard 'modular telephone' wire and connectors (see Fig. 4).

Checkout

Recheck wiring one last time and make sure that the temperature sensor(s) is plugged into the proper jack(s). The sensor(s) are only detected during power-up. Set the HEATMANAGER™ switch to 'Off/Bypass' and restore power to the boiler. Reset the switch to 'On'. After a brief check of the electronics, the sensor(s) will be detected and the green 'Power/Normal' indicator should light continuously. It is important to verify recognition of the sensors by viewing the temperature reading(s), on the display. If the installed sensor(s) are not detected, the HEATMANAGER™ will not function properly. If the green indicator is blinking or if the display does not verify the installed sensor(s), turn The HEATMANAGER™ 'Off' and check the sensor installation. After the sensor-check, depending upon the temperature of the boiler water at power-up, the HEATMANAGER™ will go into one of its various modes. If the HEATMANAGER™ goes into the 'Standby Mode'; note the aquastat setting and force a burner call by temporarily setting the aquastat higher and verifying the change of mode of the HEATMANAGER™. Make sure to return the aquastat to its' original setting. This indicates the unit is operating normally. If the HeatManager™ does not come out of 'STANDBY MODE' when the boiler's aquastat is calling for the burner to run, the unit is probably wired incorrectly; see the WIRING NOTE.

Service and Troubleshooting

After installation, the HeatManager™ requires no maintenance and will provide years of trouble free operation. The unit may be disconnected at any time by putting the switch to the 'OFF/BYPASS' position. In this position, the unit has no effect on the system and the boiler functions as it was prior to the IntelliCon installation. This allows service personnel to diagnose any boiler problems without the unit intervening.

If at any time the 'SENSOR FAILURE' message appears on the front panel display, a sensor is not operating and the unit automatically returns full control to the Boiler's aquastat. To correct this, leave the power switch in the 'ON' position and unplug each sensor from the unit (one at a time) and reconnect them. If the error message remains, a sensor is defective and must be replaced. Since it is improbable for two sensors to fail at the same time, a new sensor should be swapped with the existing sensor(s), one at a time, to determine which sensor has failed.

Here again, the power switch must be left in the 'ON' position while changing the sensors.

NOTE: Installer, please leave these instructions with the unit for future reference.

LIGHT COMMERCIAL HYDRONIC HEATING SYSTEM ECONOMIZER

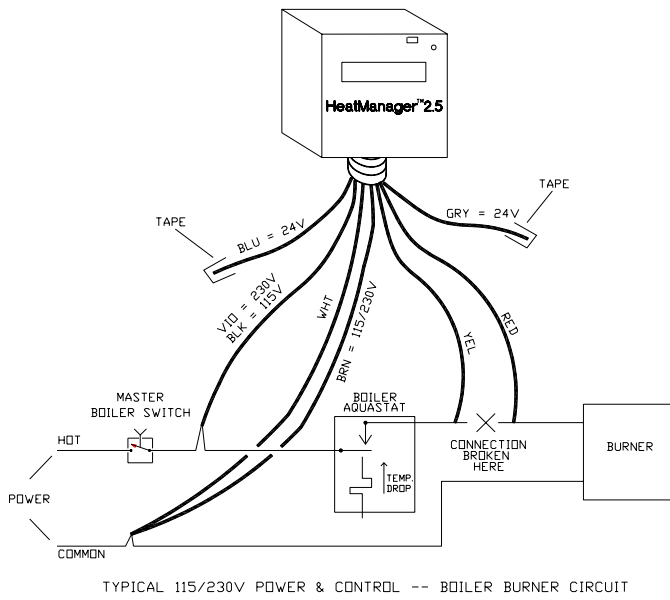

Fig. 1a

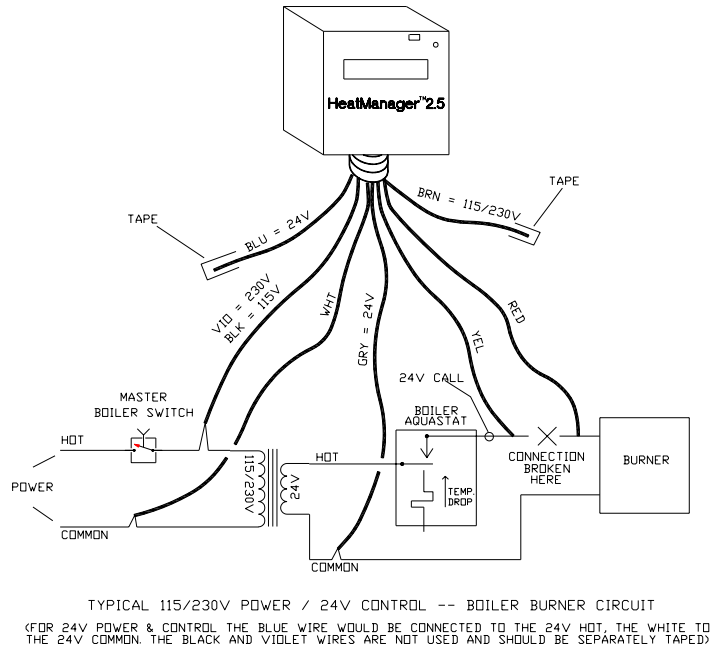

Fig. 1b

WIRING NOTE: The HeatManager™ 2.5 has separate return wires for the Power and Burner circuits. It is necessary that these wires be connected to the appropriate returns for the circuit. If this is not done; the unit will not function properly. Unused wires **MUST** be separately taped!

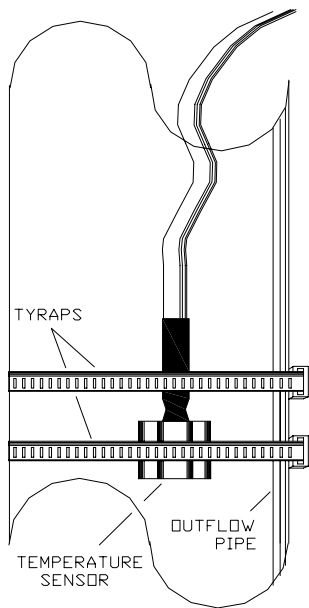

Fig. 2

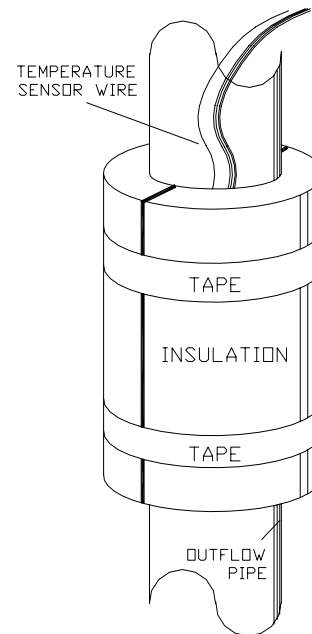
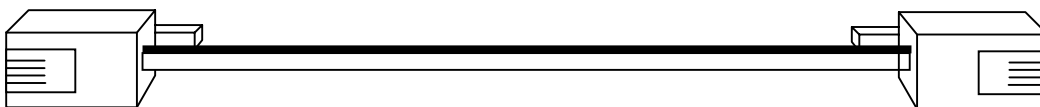

Fig. 3



The temperature sensor wire(s) can be extended using standard, 4 conductor modular telephone wire, connectors, and couplers. The correct extension wire would have the same order of wire colors, from top to bottom, with the connectors held as shown above.

Fig. 4